

AGV's – a new vision on safety and increased production efficiency

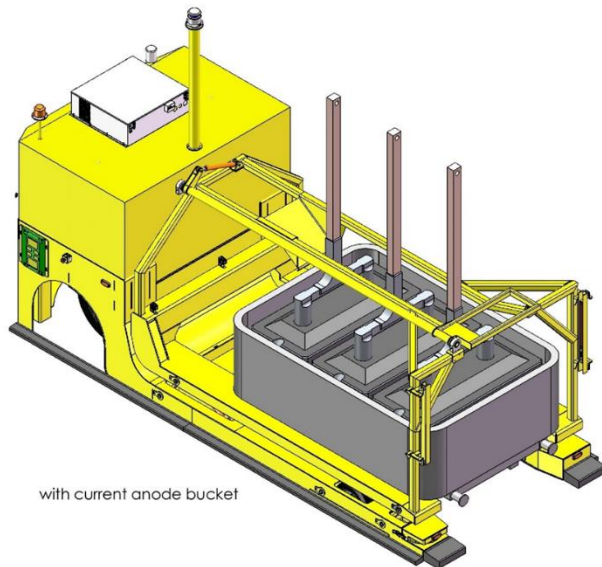

Hencon: The first operating AGV's in Aluminum Industry

When Hencon started as a company, the focus was on building quality machines for Aluminum Industry.

Together with increasing experience and know-how, Hencon felt that industries were more looking for suppliers who are able to think with them about strategic choices, about how to facilitate in their production processes and about how to improve safety and climate in their plants.

Low emission of the machines and a zero-tolerance on accidents are parameters that become crucial. In the meantime, higher productivity and increasing competition are factors that cannot longer be denied.

Several high-profile trendsetting customers of Hencon are looking for possibilities to set up a **'smart factory'**, as soon as possible.

Cyber-physical production systems are not just a far dream any longer, with Industry 4.0. a new way of thinking is born.

Hencon has rolled out several AGV projects in Europe already. The first project in the USA will be commissioned in autumn of 2019. We believe that AGV's will be an inevitable chain in the smart industry of the future.

Smart Industry and AGVs

The trend towards more automated, intelligent and interconnected systems is often referred to as Smart Industry or Industry 4.0.

AGVs fit perfectly into this trend, in the first place because they operate fully autonomously.

They connect to all other systems, such as the traffic management system, on its turn connected to the plant's Manufacturing Execution System.

An almost unlimited amount of data, such as the AGV's live positions, battery status and readings from their scanners and sensors, can be made available for data gathering software, for example via OPC UA.

In this way, a fleet of AGVs equipped with state-of-the-art sensors can - besides their primary task - serve as a troop of 'explorers', constantly collecting data on its trips through the plant, to feed a constantly updated model or visualization of the state of the plant.

The collected information helps operators and plant managers to make better decisions based on actual and historical data. All this collected operational information is kept within the plant's own protected network - so cyber-security is assured.

Specific challenges

Hencon wants to offer the right products, services and solutions, to get ready for those new needs and started to develop Automatic Guided Vehicles.

The first challenge that needed to be tackled, in order to respond to Smart Industry requirements, was the specific environment in Aluminum Plants.

Dust, electromagnetic fields and extreme temperatures are the conditions under which AGV's – highly precise technological machines – need to operate (in potrooms).

Another remarkable change that grew into the organization was the way in how to interact with its customer. 'In the old days', customers ordered machines for a well-specified purpose. Nowadays there is a continuous dialogue between Hencon and its customers, during which solutions for a smart industry are born progressively, after a mutual exchange of ideas, and the will to achieve goals that have never been set before. The relationship resulting from this kind of collaboration is based on mutual trust and the ambition to set new standards and can rather be described as a solid and durable partnership than as a traditional customer-supplier relationship.

In the paragraphs below, I will highlight two aspects:

- Safety
- An example of how AGV's increase efficiency (in this specific case: Furnace Charging Vehicles)

Safety: new target = zero accidents

Safety is always priority number one because, although AGV's are conceived to operate totally autonomously, the reality is that in most of the factories it is impossible to avoid situations in which machines and human being cross their paths.

Therefore, Hencon equips its AGV's with the latest/state of the art safety features, giving a significant improvement on worker's safety. Our vehicles have all systems on board to detect humans wherever they might appear, and to avoid accidents. If people have been detected, the AGV will slow down or stop completely, long before a collision takes place.

Impression of a typical setup of person- and object detection scanning fields on an AGV:

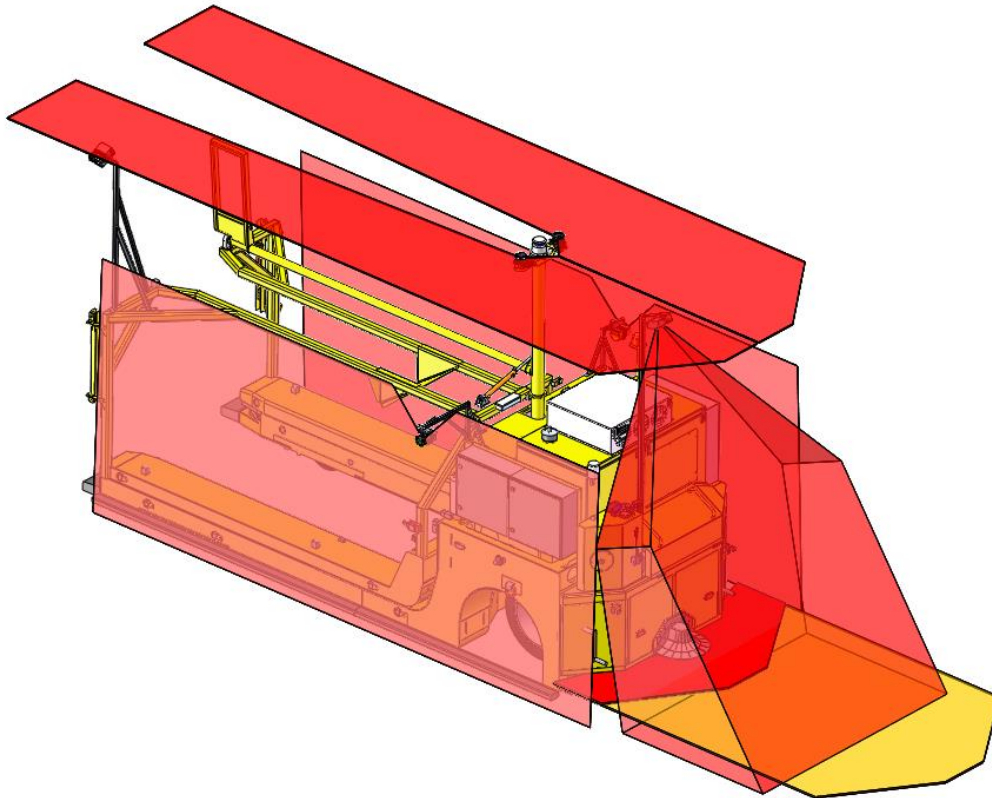

A 100% safe environment is at the benefit of every party involved and it must be emphasized that realization of AGV's, but even more the implementation of the final product in a real-life environment can only be successful under the condition of a strong relationship between both parties: The customer and Hencon. It takes a lot of time and mutual efforts.

An example of how AGV's increase efficiency

Example: furnace charging AGVs – high precision allows to make a vehicle as big as the furnace

- Dimension of AGV matches furnace door opening size and minimizes heat from escaping the furnace;
- High charging capacity per batch (>10t per batch is possible) minimizes the open time of the furnace door and therefore minimizes heat loss and energy consumption even further;
- Automating transport between the scrapyards and the hot furnaces take away people from the hot furnaces. They can focus on charging containers with the right type and amount of scrap, after which the AGV will take care of the rest.
- In a typical setup of a furnace charging system with AGVs, the container is loaded with scrap while it is off the vehicle. By this means, the AGVs can be utilized much more efficiently compared to scrap charging machines with a non-exchangeable container

- Compared to conventional (automatic) rail-bound charging systems they are much more flexible: instead of requiring to be charged near the furnace, the AGVs can drive to the scrapyards themselves to pick up a container that is filled with a load of scrap. When not in use, the AGVs can park anywhere, without obstructing access to the furnace.
- AGV's can be charged and loaded at the same time (while docking on the loading station, the battery will be charged at the same time) . This is a tremendous step forward in time-efficiency

Thanks to all these steps, cycle times have been considerably shortened. Compared to furnace charging with traditional machines, an AGV fleet is for all these reasons smaller than a traditional fleet. In addition to this, the relatively simple set-up of our vehicles also leads to maintenance costs which are reduced to an absolute minimum and a durability of the vehicle that can be doubled compared to operator driven vehicles.



Overview: Benefits of AGV's

AGVs will contribute to the efficiency of all kinds production processes and all kinds of logistical processes while increasing safety and reducing costs. The following benefits and properties can be identified:

- Suitable for picking up, transporting and unloading any load (fluid aluminium, anodes,...)
- Electrifying the powerpack leads to zero emission and less noise
- Low costs (maintenance costs are extremely low, personnel costs are reduced tremendously) (in combination with a much higher output)
- 100% Safety (no personnel involved)
- Constant communication between machine and supervisors
 - System helps to track & trace quantities and locations of the transported materials)
 - Remote and even off-site monitoring of operation
 - Remote OEM support
- The AGV will be directed via a Supervision system to the specific locations that are indicated by the Manufacturing Execution System (MES). This guarantees that the AGV is always at the right time at the right place and ensures the best production efficiency
- Machine works 24/7 with an unprecedented reliability
- More compact machines (no cabin required, no combustion engine)
- Complying with specific needs of Industry 4.0
- **A beneficial collateral effect of AGV's is that an AGV moves in a much more predictable and controlled way than a human-operated vehicle** (e.g. it doesn't bump into its load when picking this up).

This – in combination with the lack of an operator's cabin, electric engine etc. - results into a much lighter construction than conventional vehicles.

Thanks to this, impressive energy consumption can be achieved and floor loads are lighter as well, allowing further maximization of transport capacity of transport vehicles within the same floor load limitations, by pushing the vehicle/cargo weight ratio further.

Because our AGV's are much more compact than traditional machines, they are also able to enter areas with limited width/height - where a human driven vehicle would be too large.

If you'd like to know if / how AGV's can be applied in your industry, Hencon is at all time available for more detailed information. Appointments can be made at the customer's offices or at Hencon's.

Website

www.hencon.com

Editor: Peter Vanvuchelen
Director Business Development
Hencon BV